

SONY.

DIGITAL AUDIO PROCESSOR

PCM-601ESD

OPERATING INSTRUCTIONS Page 4

Before operating the unit, please read this manual thoroughly and retain it for future reference.

MODE D'EMPLOI Page 20

Avant la mise en service de cet appareil, prière de lire attentivement ce mode d'emploi que l'on conservera pour toute référence ultérieure.

BEDIENUNGSANLEITUNG Seite 36

Lesen Sie vor der Inbetriebnahme diese Bedienungsanleitung sorgfältig durch, und bewahren Sie sie zum späteren Nachschlagen gut auf.



For the customers in the United States

OWNER'S RECORD

The model and serial numbers are located at the rear.
Record the serial number in the space provided below.
Refer to these numbers whenever you call upon your
Sony dealer regarding this product.

Model No. PCM-601ESD Serial No. _____

WARNING

**To prevent fire or shock hazard, do not
expose the unit to rain or moisture.**

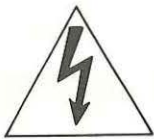
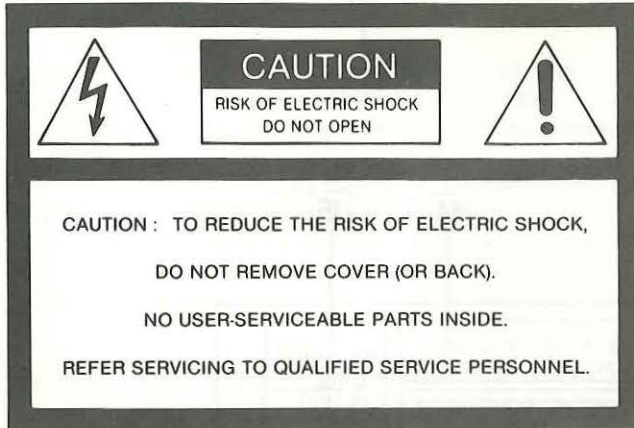

This symbol is intended to alert the user to the presence of uninsulated "dangerous voltage" within the product's enclosure that may be of sufficient magnitude to constitute a risk of electric shock to persons.



This symbol is intended to alert the user to the presence of important operating and maintenance (servicing) instructions in the literature accompanying the appliance.

INFORMATION

This equipment generates and uses radio frequency energy and if not installed and used properly, that is, in strict accordance with the manufacturer's instructions, may cause interference to radio and television reception. It has been type tested and found to comply with the limits for a Class B computing device in accordance with the specifications in Subpart J of Part 15 of FCC Rules, which are designed to provide reasonable protection against such interference in a residential installation. However, there is no guarantee that interference will not occur in a particular installation. If this equipment does cause interference to radio or television reception, which can be determined by turning the equipment off and on, the user is encouraged to try to correct the interference by one or more of the following measures:

Reorient the receiving antenna

Relocate the equipment with respect to the receiver

Move the equipment away from the receiver

Plug the equipment into a different outlet so that equipment and receiver are on different branch circuits.

If necessary, the user should consult the dealer or an experienced radio/television technician for additional suggestions. The user may find the following booklet prepared by the Federal Communications Commission helpful:

"How to Identify and Resolve Radio-TV Interference Problems".

This booklet is available from the U.S. Government Printing Office, Washington, DC 20402, Stock No. 004-000-00345-4.

As you read, fold back the manual cover to refer to information on operation.

Au cours de la lecture, dépliez la couverture de ce mode d'emploi pour se référer aux instructions sur le fonctionnement.

Klappen Sie beim Lesen die Umschlagseite heraus, um die Bilder sehen zu können.

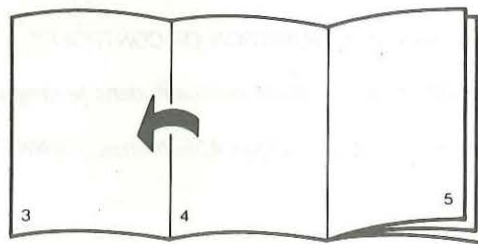

FRONT PANEL / PANNEAU AVANT / VORDERSEITE

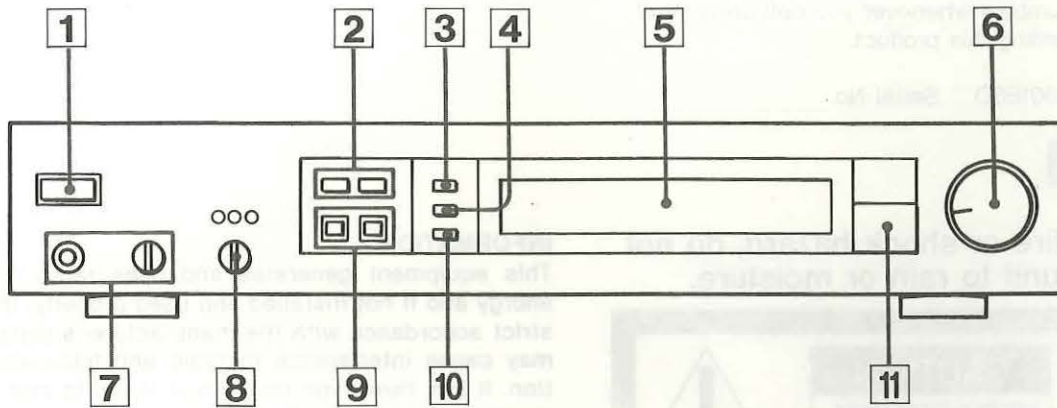

DISPLAY WINDOW / FENETRE D'AFFICHAGE / DISPLAY

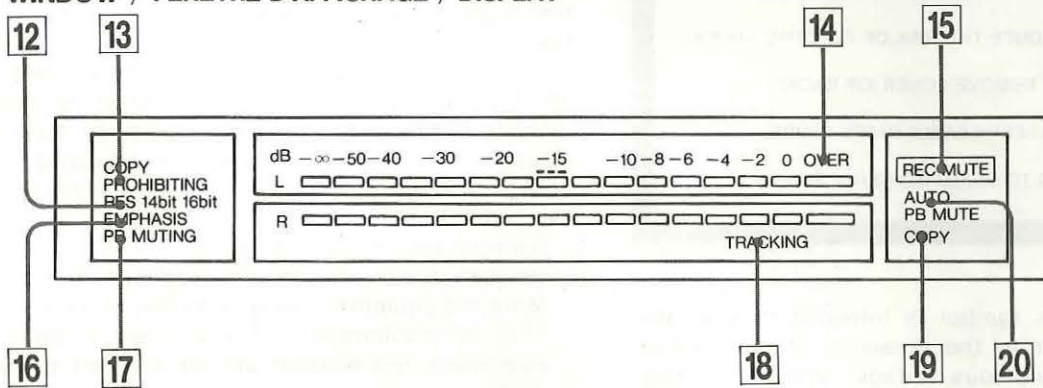

REAR PANEL / PANNEAU ARRIERE / RÜCKSEITE

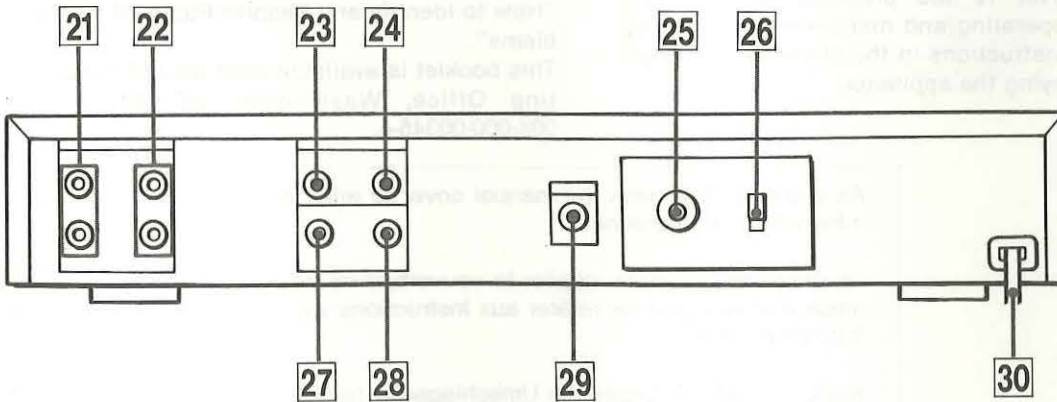

Each number is keyed to the descriptive text in "FUNCTION OF CONTROLS".

Chaque numéro trouve son correspondant dans le texte explicatif, dans le chapitre "FONCTION DES COMMANDES".

Die Nummern beziehen sich auf den Erläuterungstext des Abschnittes „FUNKTION DER BETRIEBUNGSELEMENTE“.

WARNING

To prevent fire or shock hazard, do not expose the unit to rain or moisture.

To avoid electrical shock, do not open the cabinet. Refer servicing to qualified personnel only.

For the Customers in the United Kingdom**IMPORTANT**

The wires in this mains lead are coloured in accordance with the following code.

Blue : Neutral
Brown : Live

As the colours of the wires in the mains lead of this apparatus may not correspond with the coloured markings identifying the terminals in your plug, proceed as follows :

The wire which is coloured blue must be connected to the terminal which is marked with the letter N or coloured black. The wire which is coloured brown must be connected to the terminal which is marked with the letter L or coloured red.

TABLE OF CONTENTS

Features	4
Precautions	5
Function of controls	6

OPERATION

PCM digital recording	8
Recording level adjustment	
Record muting	
Notes on recording	
PCM digital tape playback	10
Tracking adjustment of the VTR	
Automatic playback muting function	
OVC control adjustment	
Making digital tape copies	12
Timer activated recording	12

PREPARATION

Basic system connections	13
Basic connection	
Connection for digital tape copying	
Connection notes	
Other system connections	15
DA converter unit connection	
Connection of a CD player with a DIGITAL OUT jack	
Connection of multiple microphone recording	
VTR connection for monitoring video	
Specifications	18
Glossary of technical terms	19
Trouble shooting	19
Block diagram	52

The PCM-601 ESD Sony PCM digital audio processor reproduces a wide dynamic range of stereo sound with minimal distortion, low wow and flutter and a flat frequency response.

To obtain better sound quality, this equipment can also be used as an A/D (analog-to-digital) converter or as a D/A (digital-to-analog) converter.

DIGITAL IN/OUT jacks can be connected to a DA converter or a CD player with a DIGITAL OUT jack
Connect to Sony DAS-702ES DA converter unit, or a CD player with digital outputs such as the CDP-552ESD or CDP-650ESD, for quality sound reproduction.

Selectable format : 16-bit or 14-bit

Select the 16-bit format for a wide-dynamic range and low distortion, or the 14-bit format for error correction capability.

OVC (optimum video condition) control

Reads the VTR output signal and detects the VTR error condition caused by a stained head or unstable tape transport. Adjust this control to achieve a balance between the VTR and the unit for optimum performance in playback mode.

COPY OUT jack

Enables digital-to-digital tape copying with no deterioration in signal quality.

Other functions

- **Bright, easy-to-read peak program meters** enables precision setting of recording and playback levels.
- **Record muting function** enters a blank space between recordings.
- **MONITOR OUT jack** allows monitoring, regardless of the POWER switch setting.
- **AUTO PB MUTE (auto playback muting) button** enables continuous listening or double speed video playback monitoring.

PRECAUTIONS

Safety

- Check that the operating voltage of your unit is identical with the voltage of your local power supply. The European model (Type 1) operates on 220 V AC. The United Kingdom model (Type 2) operates on 240 V AC. The model for United States (Type 3) operates on 120 V AC.
- This unit has high-voltage components. Should repairs be required do not open the unit yourself; refer servicing to qualified personnel.
- Unplug the unit from the wall outlet when not in use for extended periods of time. To disconnect the cord, pull it out by grasping the plug. Never pull the cord itself.

Installation

- Do not situate the unit on uneven surfaces, unstable furniture, places where it might be subject to mechanical vibration, and where objects might fall on it. Also do not locate it in damp or humid places and areas where dust is likely to accumulate. Do not expose it to direct sunlight, extreme cold or heat.
- Good ventilation is essential to prevent heat build up inside the unit. Make sure you locate it in a well-ventilated room and do not set it on rugs, bedding or cloth-covered furnishings. Do not place anything on top of the cabinet; the top ventilation slots must be unobstructed for adequate air circulation.
- Take particular care not to set other components, especially tuners, radios and TV sets, on top or beneath the PCM unit. This could cause interference in radio and television reception.

Operation

- Before connecting the unit with other audio and video components, unplug the power cord and make sure the power switch is off.
- Use of vacuum cleaners, electric shavers, transceivers, and similar devices in the vicinity of the unit may cause noise interference and inadvertently activate the muting circuitry.
- When not using the unit, turn the power off to conserve energy and to prolong its audio life.

Cleaning

Clean the cabinet, panel and controls periodically with a soft cloth, lightly moistened with a mild detergent solution. Never use rough cloths or abrasive padding to clean the unit. Also avoid use of strong cleaners such as scouring powder of thinner, and solvents such as alcohol or benzine.

Repacking

Do not throw out the carton and packing material when practical. The carton makes an ideal container for shipping the unit off for repair work or moving it to another location. When transporting the unit, repack as illustrated on the carton.

If you have any questions concerning the operation and features of your unit, please contact your nearest Sony dealer.

FRONT PANEL

- 1 **POWER switch**
- 2 **INPUT select buttons**

Press to select the program source to be recorded.

DIGITAL : Digital audio signals input from the DIGITAL IN jack.

ANALOGUE : Audio signals input from the LINE IN or VIDEO IN jacks. Signals from the VIDEO IN jack take priority over those from the LINE IN jack.
- 3 **COPY (digital tape copy) button**

Depress this button for digital-to-digital tape copying using a pair of VTRs and the COPY OUT jack. Be sure to release this button when digital tape copying is completed.
- 4 **AUTO PB MUTE (automatic playback muting) button**

Depress this button during playback to activate the muting function and to eliminate noise caused by VTR dropouts.
- 5 **Display window**
- 6 **REC LEVEL (recording level) controls**

Adjust the recording level. The outer control governs the left channel, and the inner control governs the right channel.
- 7 **HEADPHONES jack (stereo phone jack) and LEVEL (headphone level) control**

Enables monitoring of playback or recording, and adjustment of the headphone level.
- 8 **OVC (optimum video condition) control and indicators**

First, depress the TRACKING button and then adjust this control to make good balance between this unit and a VTR.
- 9 **REC RESOLUTION (record resolution) select buttons**

Select the appropriate format for the desired resolution. Under normal operation, depress the 16-bit button.

14-bit : Press this button to record with the 14-bit format.

A tape played back on a processor with a 14-bit format, is recommended to be recorded with the 14-bit format.

16-bit : Press this button to record a tape with the 16-bit format. The 16-bit format produces recorded tapes with a wider dynamic range and less distortion than those recorded with a 14-bit format.
- 10 **TRACKING button**

Depress this button before adjusting the tracking of the video tape on the VTR. The tracking meter appears in the display window in place of the peak program meters. Each time the button is pressed, the meter function changes.
- 11 **REC MUTE (record muting) button**

Keep this button depressed to eliminate unwanted material and to enter a blank space between recorded selections.

DISPLAY WINDOW

- 12 RES (resolution) indicator**
During recording : Displays the record resolution (14-bit or 16-bit) selected by the REC RESOLUTION select button.
During playback : Displays the resolution of the tape being played, regardless of the setting of the REC RECSOLUTION select button.
- 13 COPY PROHIBITING indicator**
Lights up when playing back a tape with a tape copy prohibition code is played back or when a CD (compact disc) source input from the DIGITAL IN jack is played back.
- 14 OVER indicators**
Light up when the recording level signals exceed "0" dB, to warn that the recording level is too high.
- 15 REC MUTE (record muting) indicator**
Lights up while the REC MUTE button is depressed.
- 16 EMPHASIS indicator**
Lights up when a tape recorded with emphasis* is played back or recorded.
*This unit's emphasis circuit automatically activates when a tape recorded with emphasis is recorded or played back. This function gurantees optimum sound and increases the signal-to-noise ratio of digital tapes.
- 17 PB MUTING (playback muting) indicator**
Lights up, regardless of the AUTO PB MUTE button setting, when the VTR is not transportating the tape at the proper speed, such as at the beginning of tape playback, or when frequent dropouts occur.
- 18 TRACKING indicator**
Lights up when the TRACKING button is depressed. The R meters indicate the VTR's tracking condition, and move to the right as tracking improves.
- 19 COPY indicator**
- 20 AUTO PB MUTE (automatic playback muting) indicator**

REAR PANEL

- 21 LINE IN (line input) jacks (phono jack)**
Connect to REC OUT (recording output) jacks of an audio amplifier or to the LINE OUT jacks of a stereo microphone amplifier.
- 22 LINE OUT (line output) jacks (phono jack)**
Connect to the TAPE IN (tape input) jacks or AUX IN (auxiliary input) jacks of an audio amplifier.
- 23 VIDEO IN (input) jack (phono jack)**
Connect to the VIDEO OUT (output) jack of the VTR.
- 24 VIDEO OUT (output) jack (phono jack)**
Connect to the VIDEO IN (input) jack of the VTR.
- 25 DIGITAL OUT (output) jack (phono jack)**
Connect to the DIGITAL IN (input) jack of equipment, such as the DAS-702ES DA converter unit.
- 26 DIGITAL OUT switch**
Set to ON when connecting the DIGITAL OUT jack. **Set to OFF when not in use.**
- 27 MONITOR OUT (output) jack (phono jack)**
Connect to the VIDEO IN (input) jack of a component TV or a video monitor.
- 28 COPY OUT (output) jack (phono jack)**
Connect to the VIDEO IN jack of a second VTR to make digital tape copies.
Note : Do not connect the COPY OUT jack during normal recording or playback. Connecting it instead of the VIDEO OUT jack may adversely affect recording or playback.
- 29 DIGITAL IN (input) jack**
Connect to the DIGITAL OUT jack of a CD player, such as the Sony CDP-552ESD or CDP-650ESD.
- 30 Power cord**

PCM DIGITAL RECORDING

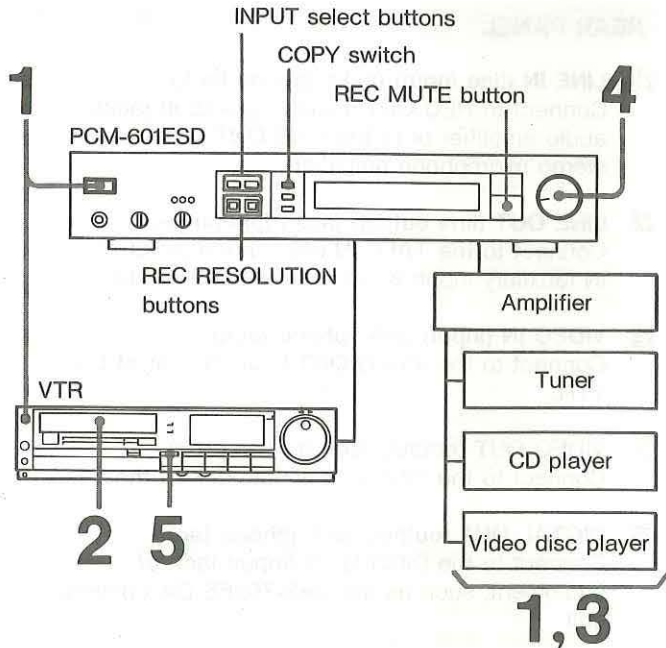

Set the switches below to the appropriate position or press the appropriate button.

VTR	Input select switch (if equipped)	LINE
	PCM switch (if equipped)	PCM
PCM-601ESD	INPUT select buttons	DIGITAL or ANALOGUE (Select according to the input source.)
	COPY switch	OFF
	REC RESOLUTION buttons	16 bit (During normal use)

- 1 Turn on the connected equipment.
- 2 Insert a video cassette.
- 3 Press the appropriate function select button of an amplifier and play the program source.
- 4 Adjust the REC LEVEL controls so that the red OVER indicators on the peak program meters illuminate occasionally at the highest signal level (See "Recording level adjustment".)
- 5 Start recording on the VTR.

Notes

- It is not necessary to adjust the REC LEVEL controls when recording a source input from the DIGITAL IN jack.
- When the DIGITAL IN jack is not connected, the incoming source from the LINE IN jack will be recorded as an analog source regardless of the INPUT select button setting.
- Refer to the VTR instruction manual on details on operation.

To monitor the recording

Be sure that the PCM-601ESD VIDEO IN jack is connected to the VTR VIDEO OUT jack. Otherwise, the peak program meters will not indicate the PCM-601ESD monitoring level and monitoring can not be made.

To record two tapes simultaneously

Connect the second VTR's VIDEO IN jack to the PCM-601ESD's COPY OUT jack.

RECORDING LEVEL ADJUSTMENT

Adjust the recording level with the REC LEVEL controls so that the peak program meters do not deflect over 0 dB.

The red illumination of the OVER indicators warns of an overload during recording. If the indicators illuminate frequently, the recording level is set too high (this will result in overload and distorted recording). As the peak program meters used in this unit are far more sensitive than conventional VU meters, also be careful not to set the recording level too low, as the signal-to-noise ratio will deteriorate. The correct recording level settings vary with the program source you are recording. Generally, adjust the level to about 15 dB.

The emphasis circuit automatically activates during recording and the peak program meters indicate the emphasized input signal levels.

Note: The OVER indicators may light up frequently when a digital recording is made from a CD player, which is equipped with the DIGITAL OUT jack such as the CDP-552ESD or CDP-650ESD. The frequent lighting of the OVER indications shows that the highest CD level is being recorded, not that the sound is distorted.

RECORD MUTING

During recording, unwanted program material such as commercials can be eliminated by pressing the REC MUTE button.

When this button is pressed, no signals are recorded on the tape, but the program can be monitored through the speakers or headphones.

- 1 While recording, just before the portion to be eliminated begins, press the REC MUTE button. Keep it pressed until the portion to be eliminated ends. This button cannot be locked.
- 2 Release this button to begin recording again.

NOTES ON RECORDING

VTR

Tape speed

With the VTR, we recommend using the **I** or **II** mode. PCM recording in long play mode is not recommended.

Make trial recording.

PCM switch

Set this switch to ON to deactivate the picture compensation circuit, which is not used during PCM recording.

Even if a VTR without a PCM switch is used, the PCM-601ESD can read and compensate error data with its error processing circuit.

Be sure the video cassette tab has not been removed.

The REC (record) function does not operate if the tab has been removed. If the tab has been removed, cover the slot with plastic tape.

Do not set the unit in the pause mode for an extended period of time.

If the VTR is set to the pause mode for a long time, the video tape may be damaged. We recommend that the pause button be used as little as possible. The playback muting function may not operate in the pause mode on some VTRs and the noise may be heard.

PCM-601ESD

14-bit/16-bit setting

Press either the 14-bit or the 16-bit button before making a recording. During playback the unit detects the format with which the tape was recorded and automatically selects the 14-bit or 16-bit setting.

REC LEVEL control adjustment

Adjust the REC LEVEL control only when signals are input from the LINE IN jack. If signals are input from the DIGITAL IN jack, the recording level is automatically set to the optimum level.

COPY switch

Depress this switch to make a digital tape copy. **Be sure to set it to OFF during normal recording or playback.** A normal recording cannot be made when this switch is set to ON.

Analog tape copying

If your amplifier does not have a tape copy function, connect the LINE IN jack of a cassette deck directly to the LINE OUT of the PCM-601ESD to copy a PCM-recorded tape.

If you connect the cassette deck to the AUX or TUNER input jack of that amplifier, howling may occur and the speaker may be damaged.

PCM DIGITAL TAPE PLAYBACK

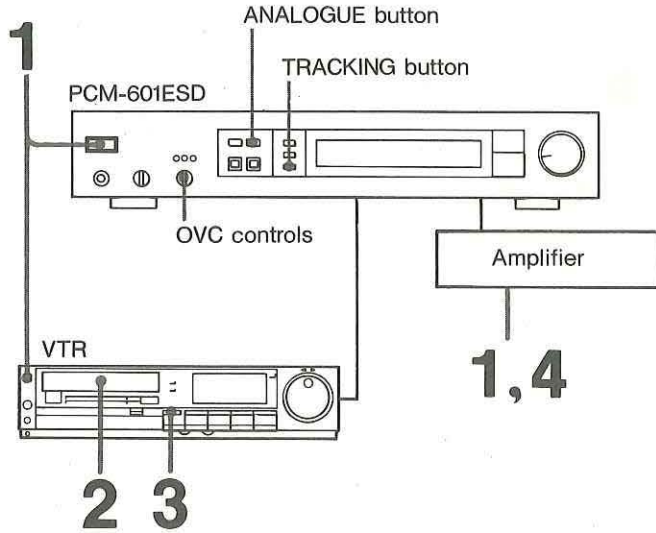

Set the switches below to the appropriate position or press the appropriate button.

VTR	Input select switch (if equipped)	LINE
Amplifier	Input selector	TAPE or CD (depending upon which is connected to the PCM-601ESD)
	Volume control	Minimum position
PCM-601ESD	INPUT select buttons	ANALOGUE

- 1 Turn on the connected equipment.
- 2 Insert a PCM recorded video cassette.
- 3 Start playback on the VTR.
- 4 Adjust the amplifier volume.

Note : Set the amplifier volume relatively low, and do not adjust it when no audio signals or a low level input are recorded. Otherwise, the speaker may be damaged when high-level signals are input, because PCM recording affords a wider dynamic range than is afforded by conventional analog recording.

TRACKING ADJUSTMENT OF THE VTR

When a video tape recorded on another VTR is played back, dropouts occasionally occur due to mistracking of the video heads. To obtain optimum sound reproduction, adjust the tracking of the VTR as follows.

- 1 Press the ANALOGUE button.
- 2 Press the PCM-601ESD TRACKING button. The TRACKING indicator lights up and the tracking meter appears in place of the peak level meters.
- 3 Insert a recorded video cassette into the VTR and set the unit to the playback mode.
- 4 After the PB MUTING indicator goes off, adjust the VTR tracking control so that the rightmost indicators light up within the permissible tracking adjustment range.

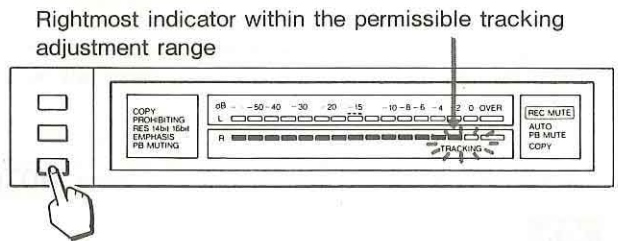

AUTOMATIC PLAYBACK MUTING FUNCTION

Press the AUTO PB MUTE button during playback to activate the muting circuit, which automatically eliminates faulty sound reproduction caused when tape playback begins or when the unit is set to the fast forward or pause modes, or when frequent dropouts occur.

If the muting circuit activates so often as to make listening unpleasant, adjust the VTR tracking control and then press the AUTO PB MUTE button to release it. This will permit you to continue listening without interruption, although a certain amount of noise will be reproduced.

Notes

- Be sure to press the AUTO PB MUTE button when recording and playing back TV programs. Otherwise the video data could be misread as PCM data and clicking noise might occur, which could damage the speakers. Clicking may also occur when a blank video tape is played back.
- The PB MUTING indicator lights up when dropouts occur, regardless of the AUTO PB MUTE button setting.

OVC CONTROL ADJUSTMENT

When playing back the tape recorded with the **III** or VHS long play mode, on which the recorded track is too narrow to correctly pick up the digital signals, set the OVC control as follows :

- 1 Press the ANALOGUE button.
- 2 Press the PCM-601ESD TRACKING button and adjust the VTR tracking function (see "Tracking adjustment of the VTR").
- 3 Turn the OVC control as follows :

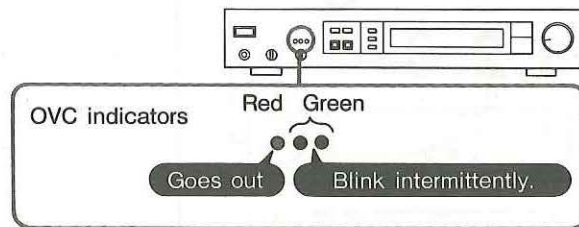

- 4 If you cannot make the adjustment this way, reset the OVC control to the center position and adjust the VTR's picture or sharpness control so that the OVC indicators light up in the manner described in step 3.

Once the optimum video condition is obtained, it is not necessary to readjust the OVC control even if red OVC indicator sometimes flashes or lights up. The built-in error correction circuit functions at that time. If the red OVC indicator frequently flashes, clean the head or replace the video tape.

Note : The OVC indicator shows the logically counted PCM data condition. Therefore, the VTR condition is checked only with the PCM data and it does not correspond to the video image condition. In general, PCM data error occurrence tends to decrease when no image or dropout compensation is applied.

MAKING DIGITAL TAPE COPIES

Recording can be made with no deterioration in sound quality, since the error data are detected and corrected in digital-to-digital copying. Recording level adjustment is not necessary.

Two VTRs are required for copying: one for playback (VTR 1) and the other for recording (VTR 2).

After making the connection illustrated on page 14, proceed as follows.

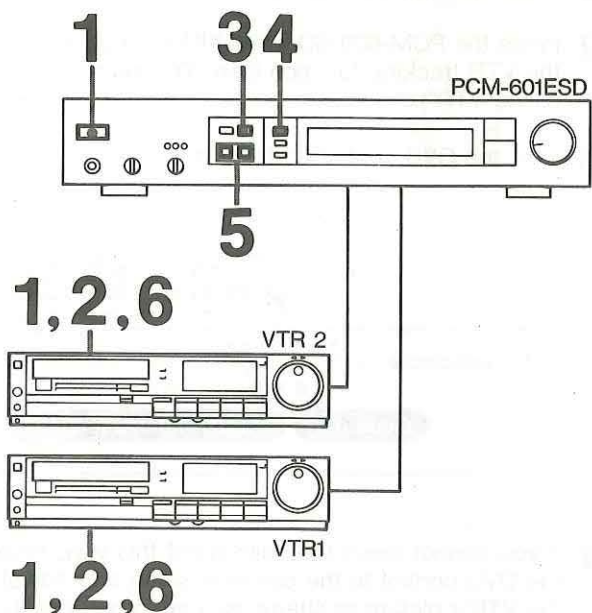

- 1 Turn on the connected equipment.
- 2 Insert a recorded tape into the VTR 1 and a blank tape into the VTR 2.
- 3 Depress the ANALOGUE button.
- 4 Depress the COPY button.
- 5 Depress either of the REC RESOLUTION select buttons: 14-bit or 16-bit. Depress the 16-bit button for normal use.
- 6 Start playback on the VTR 1 and recording on the VTR 2 to begin copying.

When copying is completed, press the COPY button again to release it.

Notes :

- Turn the amplifier volume down before depressing the COPY button. Otherwise, a clicking noise may be heard.
- When the COPY PROHIBITING indicator appears in the display window, copies cannot be made even if the COPY button is depressed.
- A tape will be copied with no deterioration in signal quality, even if sound heard through the headphones or speakers is distorted.

TIMER ACTIVATED RECORDING

Use a VTR with a timer standby switch.

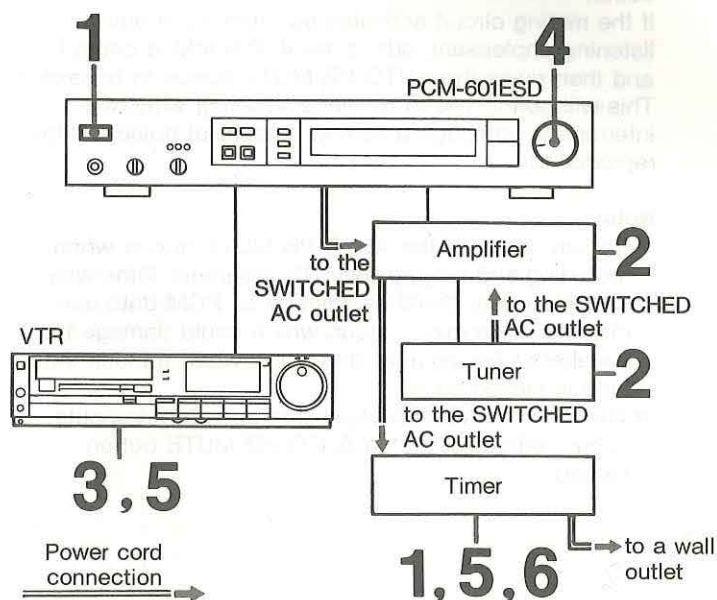

- 1 Turn on the timer and the connected equipment.
- 2 Set the amplifier function control to TUNER and tune in the station to be recorded.
- 3 Prepare the VTR for recording by inserting a cassette, setting the PCM switch to PCM, and setting the input select switch to LINE/PCM.
- 4 Adjust the recording level.
- 5 Set the ON-time and OFF-time for the recording on both the timer and the VTR.
- 6 Make the required timer adjustments to turn off all the connected equipment at the desired time.

For details, refer to the appropriate instruction manual.

BASIC SYSTEM CONNECTIONS

BASIC CONNECTION

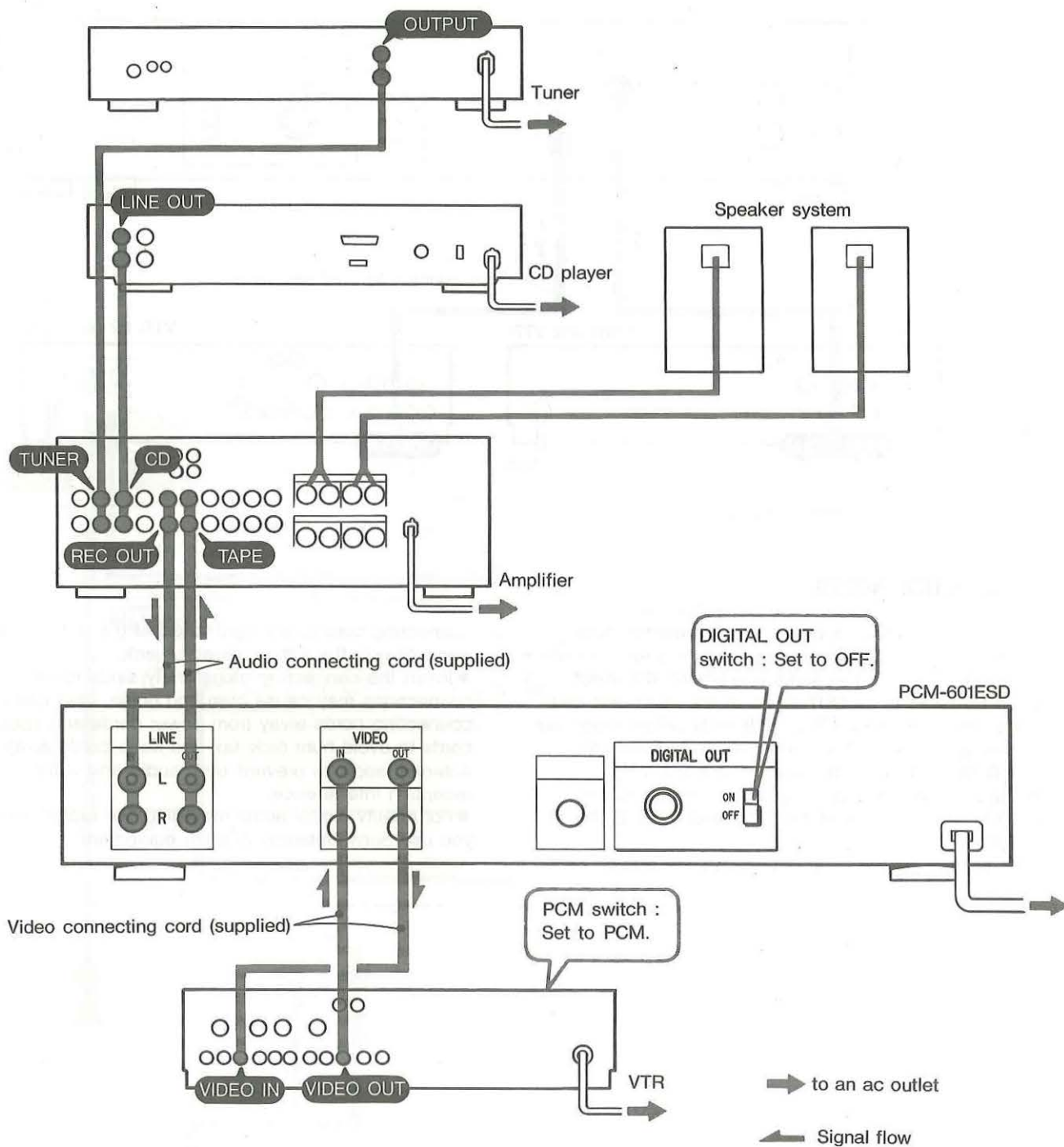

Power cord polarity

A white mark is visible on the lead of the power cord. This will help to operate the PCM-601ESD and the other system components of the system "in phase" by

aligning the ac power cord polarities with the ac outlet polarities. In most cases, the marked plug of the PCM-601ESD power cord should be inserted into the grounded side of the ac outlet.

CONNECTION FOR DIGITAL TAPE COPYING

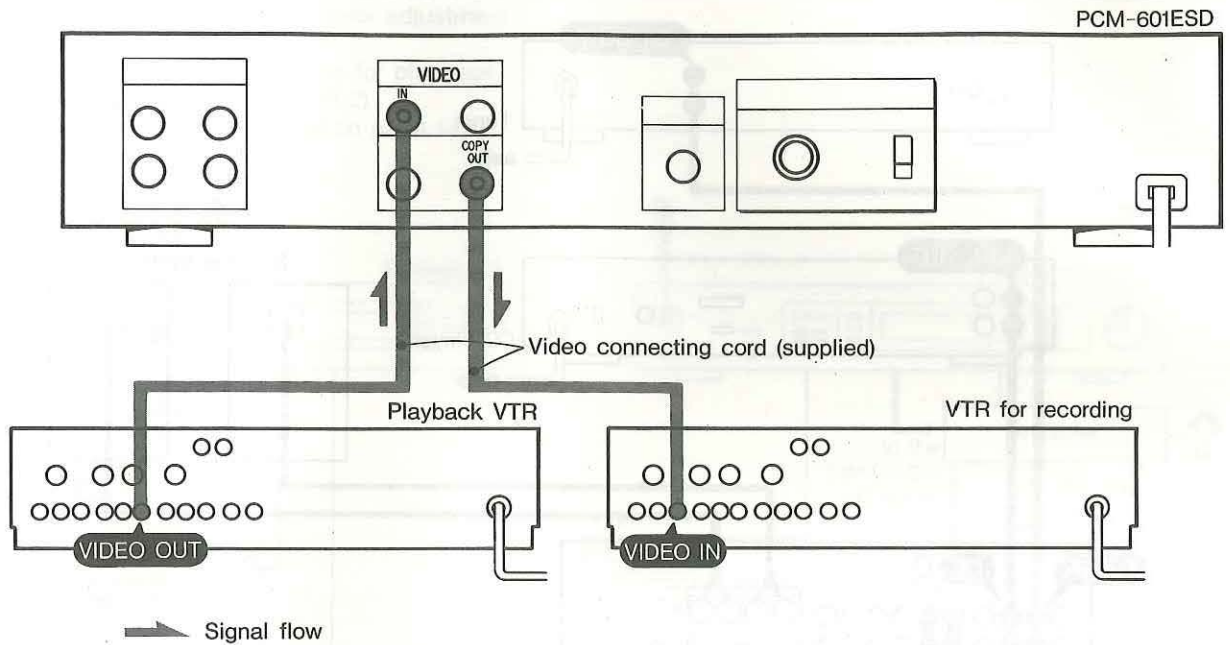

CONNECTION NOTES

- Turn off the amplifier before making connections.
- The supplied connecting cords with the red and white plugs are connected to audio equipment. (Connect these to the LINE IN/OUT jacks of the PCM unit and the audio component). The cords with yellow plugs are connected to the VTR (Connect these between the VIDEO IN/OUT jacks of the PCM and the VTR).
- The cord with orange plugs is connected to the DIGITAL IN/OUT jack of the PCM and other digital equipment.
- Be sure to connect the red plug of the audio

connecting cord to the right-channel (R) jack and the white plug to the left-channel (L) jack.

- Insert the connecting plugs firmly since loose connections may cause hum and noise. Also keep connecting cords away from power cords and speaker cords to avoid hum pick-up, and keep cords away from antenna leads, to prevent both audio and video reception interference.

- For quality digital audio recording, we recommend that you use Sony Betamax or 8mm equipment.

OTHER SYSTEM CONNECTIONS

DA CONVERTER UNIT CONNECTION

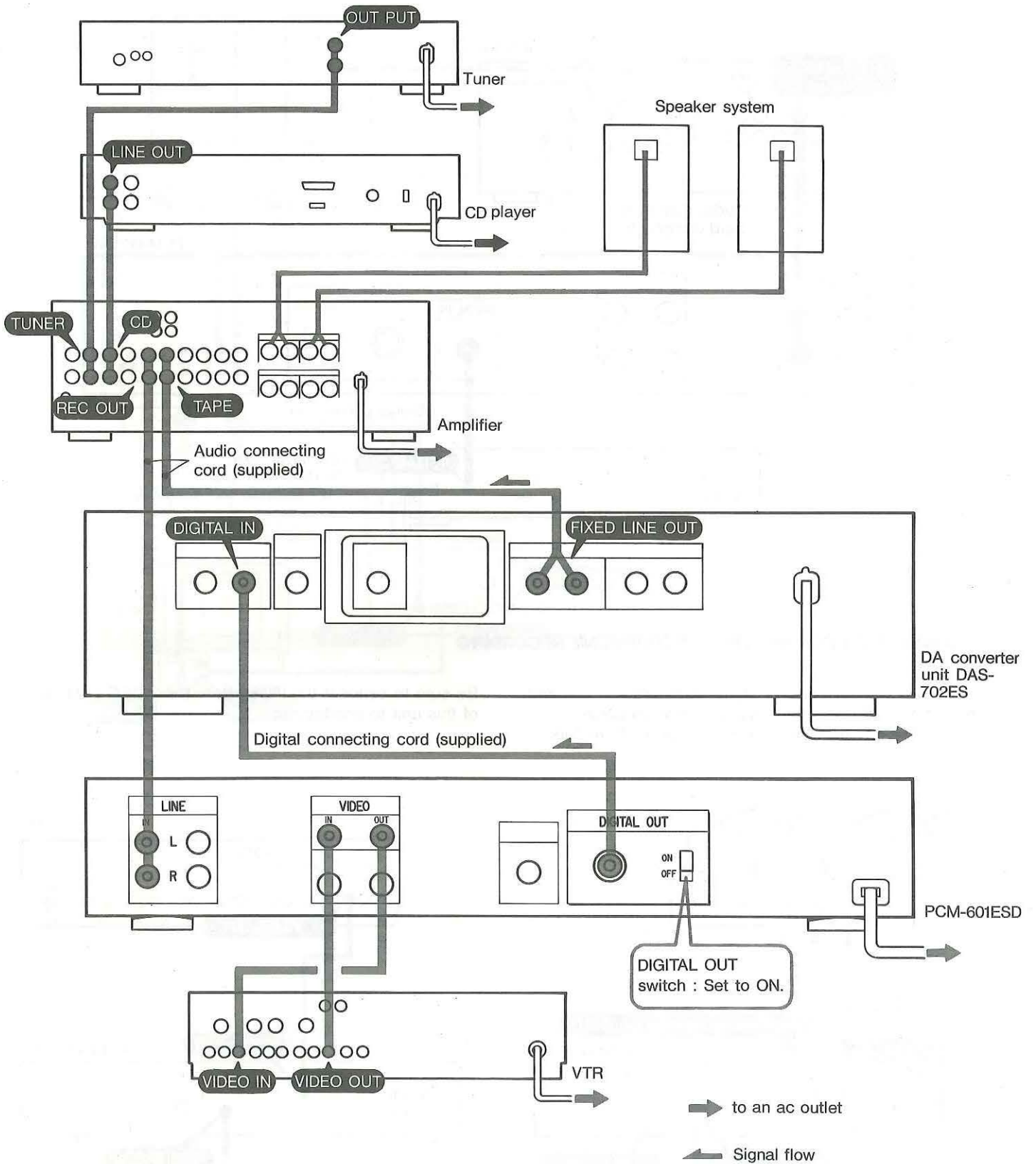

CONNECTION OF A CD PLAYER WITH A DIGITAL OUT JACK

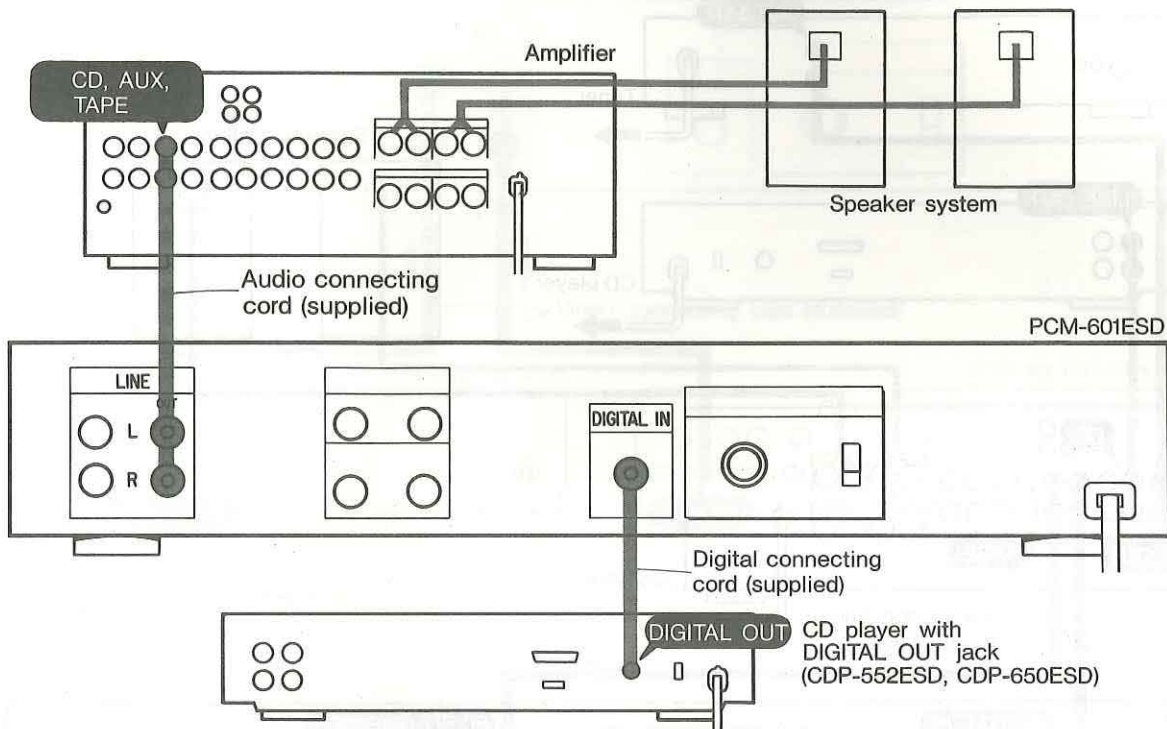

CONNECTION FOR MULTIPLE MICROPHONE RECORDING

To record without noise or signal deterioration, connect two PCM-601ESDs with a digital extension cable. This cable can be extended up to approx. 20 meters.

Be sure to connect the VIDEO IN to the VIDEO OUT jack of this unit to shortcircuit.

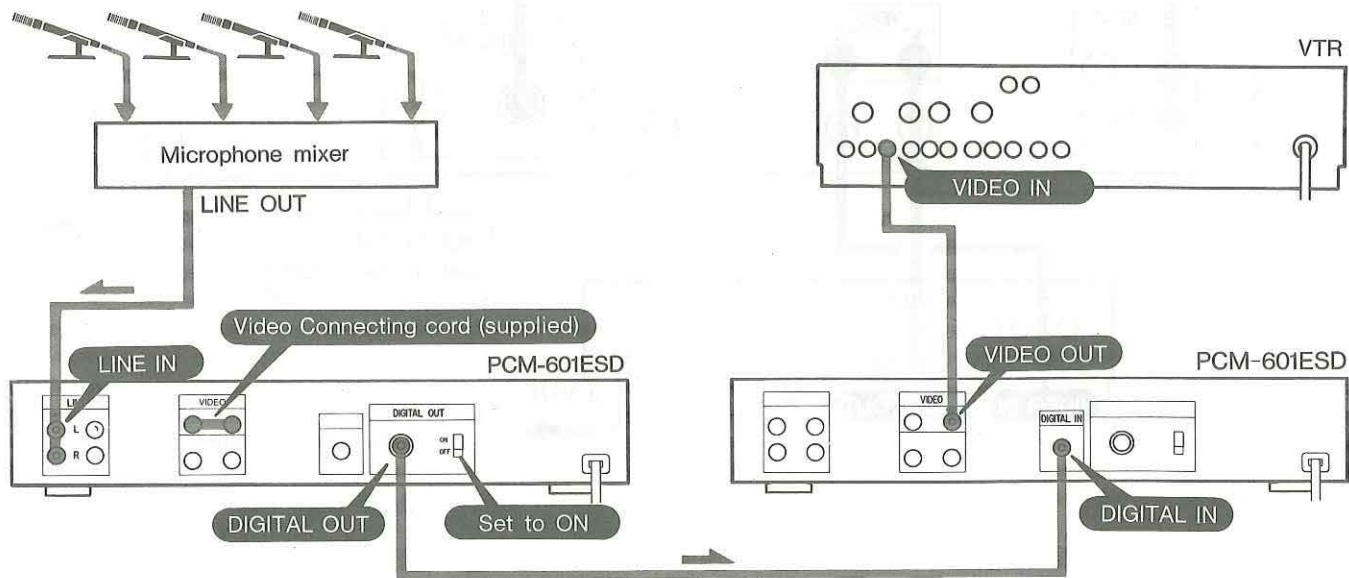

VTR CONNECTION FOR MONITORING VIDEO

Connect a color monitor to the MONITOR OUT jack of the PCM-601ESD so that one VTR can be used for both PCM recording/playback, and TV/video program monitoring.

To use VTR for PCM recording/playback
Set the POWER switch of the color monitor to OFF.

To use a VTR for TV or video monitoring
Set the POWER switch of the PCM-601ESD to OFF.

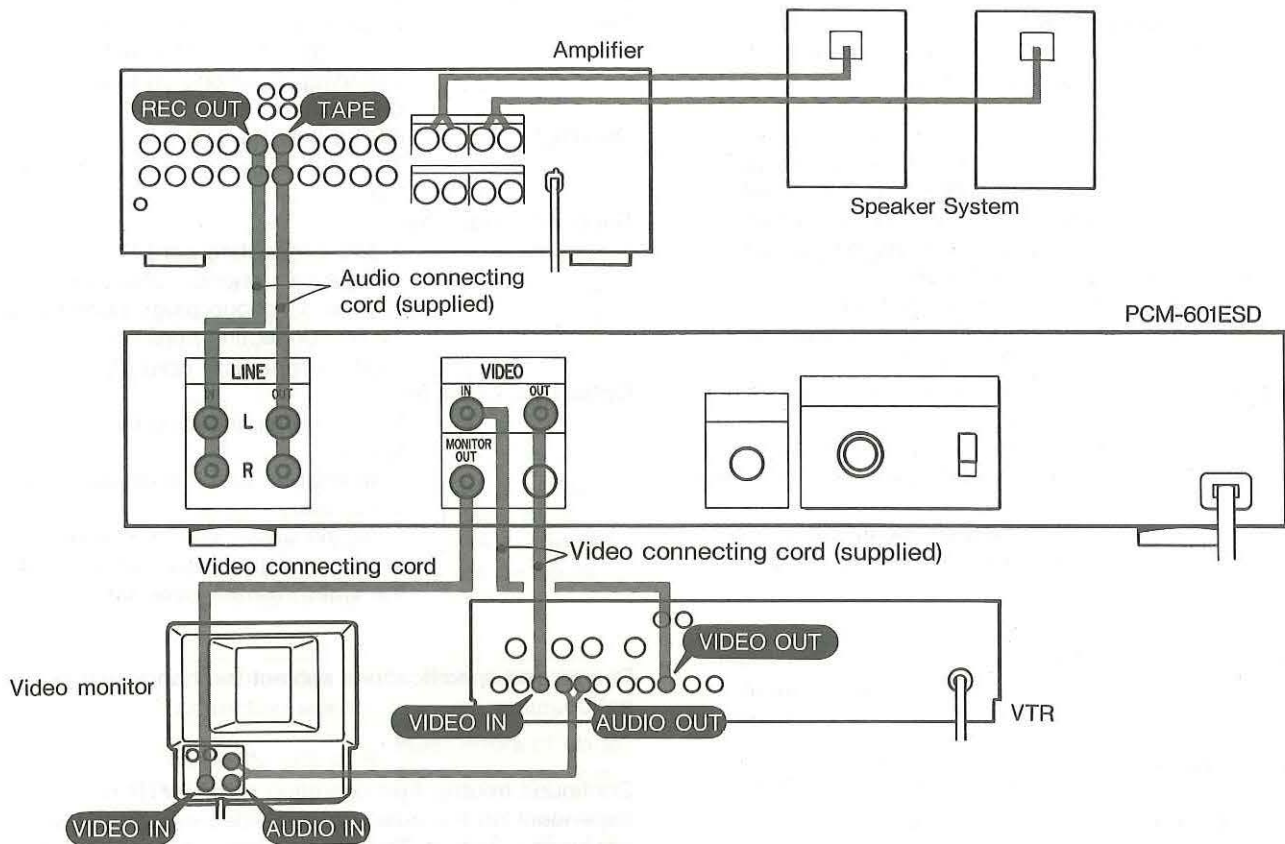

Notes :

- Keep the AUTO PB MUTE button pressed during recording or playback of TV programs. Otherwise, the signal is misjudged as PCM data, resulting in a click

- noise, which may damage the speakers.
- Do not play back a blank tape. Otherwise, noise may be heard, which also may damage the speakers.

SPECIFICATIONS

Signal system	Conforms to CCIR television standard, PAL/SECAM (type1, 2) and NTSC (type 3) color
Code format	Conforms to the technical specifications of the EIAJ (standard format using 14-bit or 16-bit quantization)
Number of audio channels	2 channels
Sampling frequency	44.1 kHz
Quantization	14-bit linear quantizing, or 16-bit linear quantizing
Frequency response	5-20,000 Hz \pm 0.5 dB
Harmonic distortion	Less than 0.007% (14-bit format) Less than 0.005% (16-bit format)
Dynamic range	More than 86 dB (14-bit format) More than 90 dB (16-bit format)
Channel separation	More than 80 dB
Wow and flutter	Below measurable limit
Error correction	Error correction and concealment using CRCC and parity
Emphasis	Pre-emphasis (on recording): fixed at ON De-emphasis (on playback): automatically switched ON or OFF (by detecting pre-emphasis identification code) Time-constant: 50 μ sec, 15 μ sec

Inputs

	Type	Reference input level	Impedance	Minimum input level
LINE IN	Phono	0.24 V (-10 dBs)	50 kilo-hms	77.5 mv (-20 dBs)
VIDEO IN	Phono	1 Vp-p	75 ohms	—
DIGITAL IN	Phono	0.5Vp-p	75 ohms	—

Outputs

	Type	Reference output level	Load impedance
LINE OUT	Phono	0.24 V (-10 dBs)	More than 10 kilohms
MONITOR OUT	Phono	1 Vp-p	75 ohms
VIDEO OUT	Phono	1 Vp-p	75 ohms
COPY OUT	Phono	1 Vp-p	75 ohms
HEADPHONES	Stereo phone	0.9-0.003 mW Continuously Adjustable	32 ohms
DIGITAL OUT	Phono	0.5Vp-p	—

General

Power requirements	Type 1: 220 V ac (or 240 V ac adjustable by authorized Sony personnel), 50/60 Hz Type 2: 240 Vac (or 220 V ac adjustable by authorized Sony personnel), 50 Hz Type 3: 120 V, 60Hz
Power consumption	33 W
Dimensions	Approx. 430 \times 85 \times 385 mm (w/h/d) (17 \times 3 ³ / ₈ \times 15 ¹ / ₈ inches) including projecting parts and controls
Weight	6.0 kg (net) (13 lb 3 oz) 7.0 kg (in shipping carton) (15 lb 3 oz)
Supplied accessories	Video connecting cord (2) Type 1,2: phono \leftrightarrow BNC plug Type 3: phono plug \leftrightarrow phono plug Audio connecting cord (2) Digital connecting cord (2)
Optional accessories	Video connecting cord UGC-1 (BNC plugs) Plug adapter EAC-58 (phono plug \leftrightarrow BNC jack) *Use the above cord and adapter jointly for digital tape copying and the video monitor hook up.

Design and specifications subject to change without notice.

Continued trouble-free operation of any VTR is dependent on the quality of the video cassettes used in conjunction with it. The use of Sony video cassettes is recommended for high quality recording and trouble-free operation.

GLOSSARY OF TECHNICAL TERMS

14-bit format and 16-bit format

The 14-bit and 16-bit formats of the PCM-601ESD conforms to the technical specifications of the EIAJ which has adopted the 14-bit and 16-bit linear quantization format.

The 16-bit format is compatible with the 14-bit, so a tape recorded with the 16-bit format on the PCM-601ESD can be played back on another PCM digital audio processor which conforms to the 14-bit format. Also a tape recorded with the 14-bit on another PCM processor can be played back on this unit, which automatically detects the format used for recording.

Error correction capability of the 14-bit and 16-bit formats

During recording with the EIAJ 16-bit format, the 14-bit format error correction word "Q" replaces the 15th and 16th bits of the data, so that the 16-bit format is compatible with the 14-bit format. For convenience, we express the word comprising the information of the 15th and 16th bits with the symbol "S" instead of the 14-bit format symbol "Q". In the 14-bit format, data contain the error correction words, "P" and "Q": in the 16-bit format, data contain only the error correction word, "P".

Accordingly, the error correction capability of the 16-bit format is inferior to that of the 14-bit format. If a tape recorded with the 16-bit format is played back on a PCM digital audio processor which conforms to the 14-bit format, the error correction capability will be equal to one parity bit of the 16-bit format.

	Usable error correction word	Error correction capability
14-bit format of the EIAJ	Two parity bits of P and Q	Burst errors of up to 32 H can be corrected.
16-bit format of the EIAJ	A single parity bit of P	Burst errors of up to 16 H can be corrected.

It should be noted that burst errors beyond the error correction capability will be compensated for so that they are not perceptible.

TROUBLE CHECKS

Should any problem persist after you have made these checks, consult your nearest Sony service facility. Before going through the check list below, first refer back to the connection and operating procedures.

Recording cannot be made.

Check the COPY button or INPUT select button setting.

The peak program meter indicator does not function when a recording is monitored.

Check the connection between the PCM-601ESD VIDEO IN jack and the VTR video output jack PCM-601ESD.

The VTR record button cannot be operated.

The video cassette tab has been removed.

The monitored sound is distorted during digital tape copying.

Even if the monitored sound is distorted, the sound being copied is recorded without distortion.

A click noise occurs when a TV program is recorded or when a recorded cassette is played back.

The AUTO PB MUTE button is released.

BLOCK DIAGRAM / SCHEMA DE PRINCIPE / BLOCKSCHALTBIKD

